

## Light Industrial Master Station

### Features

- Fully equipped splashproof master station with free access to all extensions and features.
- Flame- and chip-resistant plastic casing. Key board foil of UV-cured PVC. Resistant to corrosive fluids.
- Electret microphone and red microphone live lamp.
- Screw terminals for easy connection of installation cables.
- Built-in loudspeaker and possibility to connect an external speaker. Sound level adjustable with a potentiometer inside the station.
- Built-in 10W (8 Ohm) VOX operated power amplifier for external loudspeaker.
- Freely programmable extension number (1-, 2-, 3- or 4-digit number).

### Description

This Industrial Master Station is a splashproof model designed for humid, dirty and outdoor conditions. It can operate in an ambient temperature range from 0°C to +50°C (+32°F to +122°F). The station consists of a flame- and chip-resistant casing of durable Bayblend® plastic. The station's front plate - including the keyboard - is made of UV-cured PVC, a material which is resistant to a number of corrosive fluids. The front panel can be removed to allow easy access during installation and service. The station has screw terminals with labels for easy installation. The glands give water- and dustproof connection of the installation cable.

The station's electret microphone automatically adjusts its sensitivity according to the input level, providing undistorted audio in the internal 45 Ohm loudspeaker. The volume is adjustable with potentiometer located inside the casing. An external 20-70 Ohm speaker can be connected or, alternatively, connect an 8-20 Ohm speaker for use with the built-in 10W (8 Ohm) VOX operated power amplifier. The power amplifier requires a separate 12V AC / 2 Amp power supply. The external speaker must be placed at least one meter away from the station.

The station is programmable for permanent private mode and is also prepared for connection of external handset unit.

AlphaCom System



### Specification

<b>Order Number:</b>	<b>100 7080 000</b>
Operating Voltage:	From exchange without power amp. 12V AC / 2 Amp with power amp.
Cable Requirements:	2 pair 0.5 mm <sup>2</sup> / 24 AWG twisted telephone cable. + 1 pair 0.8 mm <sup>2</sup> / 20 AWG (to transformer if power amplifier is used)
Temperature Range:	0°C to +50°C +32°F to +122°F
Humidity Range (non-condensing):	10% - 85% RH
Dimensions: (W x H x D)	124 mm x 244 mm x 63 mm 4.9" x 9.5" x 2.5"
Classifications:	IP54
Finish:	Bayblend® plastic. Keyboard of UV-cured PVC (which is resistant to Ethyl-Alcohol, White Spirit, Alkali, Battery Acid, Methanol, Hydrochloric Acid, Citric Acid, Antifreeze, Insecticide, Cola, Disinfectants, Motor Oil, Detergents, etc.)
Sound pressure at 1m from internal speaker:	66 dB (0.5 mm cable x 100 m, 8.0V on subscriber board, 1 kHz)
Max. loudspeaker output - external speaker:	1.5W (20 Ohm) 10W (8 Ohm) w/power amplifier
Loudspeaker Impedance:	45 Ohm (built-in speaker) 20-70 Ohm external (without pow. amp.) 8-20 Ohm external (with power amp.)
Frequency Range:	500-5000 Hz (± 8 dB)
Mic. Impedance for external handset:	200 - 600 Ohm
Connector Type:	Screw terminals
Gland Diameter:	1 x PG9, 1 x PG11
Indicator:	LED (red)



**STENTOFON**

**100 7080 000**

STENTOFON products are developed and marketed by ZENITEL NORWAY AS. The company's Quality Assurance System is certified to meet the requirements in NS-EN ISO 9001:2002. ZENITEL NORWAY AS reserves the right to modify designs and alter specifications without prior notice, in pursuance of a policy of continuous improvement.

# Light Industrial Master Station

## Installation

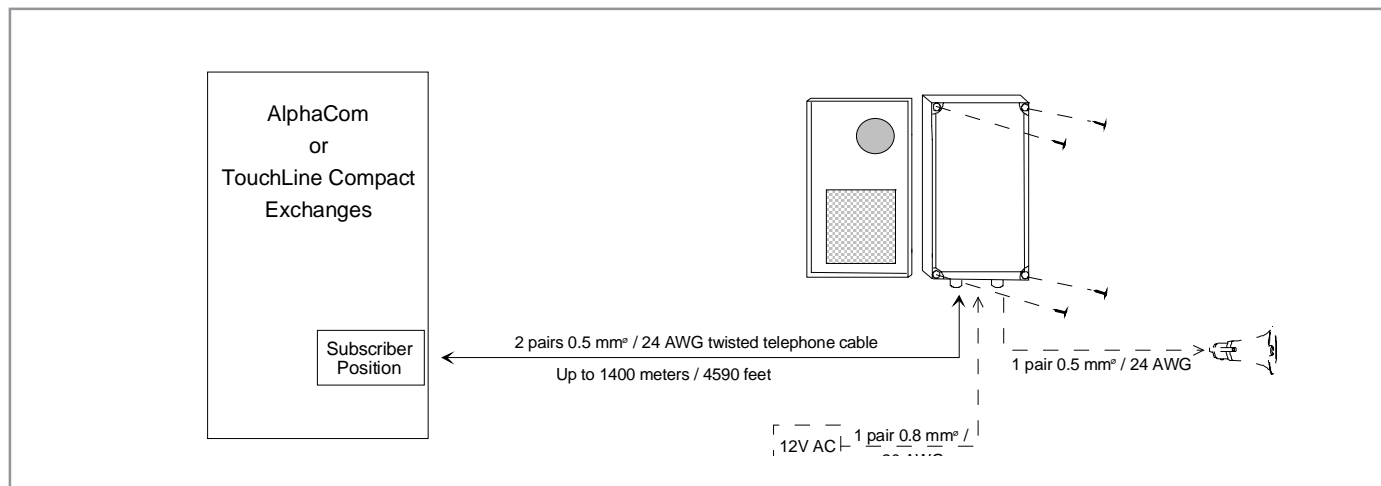

## Wiring

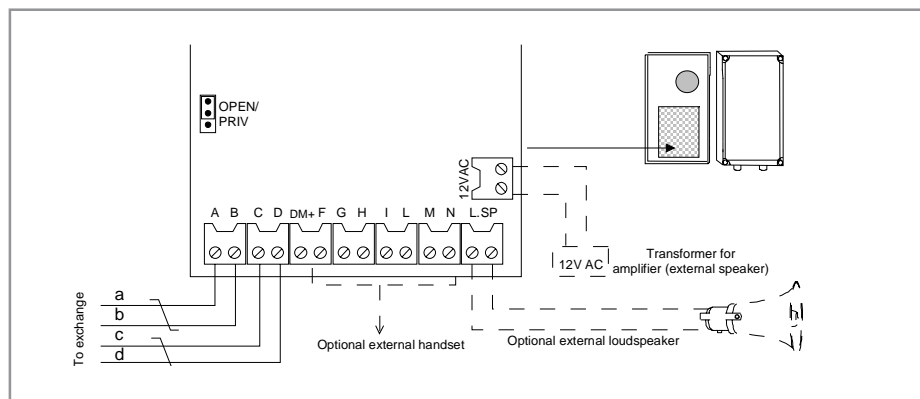

## Ordering information

Order Number	Description	Ship Weight metric/imperial
100 7080 000	Light Industrial Master Station (IP54, with loudspeaker)	0.9 kg / 2 lb.
<b>Supplementary equipment:</b>		
HP 10	10 W / 20 Ohm Horn Speaker, IP 55	1.0 kg / 2.2 lb.
HP 15	15 W / 20 Ohm Horn Speaker, IP 55	1.4 kg / 3.1 lb.
HS 15	15 W / 20 Ohm Horn Speaker, IP 67	2.3 kg / 5.1 lb.
EOTRF 10115	220V AC / 12V AC Mains Transformer (for power amplifier option)	1 kg / 2.2 lb.



Zenitel Norway AS  
www.zenitelcss.com  
info@zenitelcss.com

