

▶ Polycom® HDX 4000™ Series

Premier Personal Communication Solution



The ultimate executive desktop telepresence solution for high-definition video conferencing, audio and content sharing

Performance-engineered to deliver high-definition visual communication, the Polycom® HDX 4000™ Series delivers the premium rich-media desktop system, redefining the personal communication experience. Merging an extraordinary degree of visual and acoustic clarity with powerful functionality, Polycom HDX 4000 Series systems bring unprecedented immediacy to video conferences, audio interactions and content exchanges.

High-Definition Visual Communication

Polycom HDX 4000 Series systems leverage decades of design innovation and the legendary quality of Polycom to deliver the premium desktop system for rich-media communication. With a 20.1" video screen, an acoustically superior stereo sound system and modern, streamlined design, Polycom HDX 4000 Series systems combine professional-level visual communication with full PC and Mac monitor functionality.

Built to high-definition-television (HDTV) industry standards, screen colors are more vibrant, movements smoother and expressions unmistakable. Polycom HD Voice™ technology, delivered through dual, built-in microphones, enables users to hear remote participants' voices in stereo, while advanced four-way speakers deliver astonishingly life-like audio. As a result, interactions with colleagues and partners, across campus or around the globe, are more natural than ever. Polycom HDX 4000 Series systems also offer greater flexibility for conferencing, with an optional embedded multipoint feature that allows multiple locations to be brought online quickly and easily.

Content Collaboration Made Easier Than Ever

Polycom HDX 4000 Series systems also include powerful tools for content sharing. Presentations, graphics, spreadsheets and multimedia files can be incorporated into visual communication, facilitating collaboration and quicker decision making. Additionally, with Polycom People On Content™ embedded chroma key technology, the user's image can be inserted into the foreground of the content and appear to be part of the presentation.

Find Out More

Learn what the Polycom HDX 4000 Series can do for your organization. Visit us at www.polycom.com or contact your Polycom representative.

Benefits

- ▶ High-definition video conferencing – Natural communications in 1280 x 720 at 30 fps (720p), with exceptional resolution even at lower data rates
- ▶ High-definition voice – Polycom Siren™ 22 technology for high-fidelity stereo sound
- ▶ High-definition content sharing – Polycom collaboration technology for sharing graphics, presentations and rich-media content with HD and non-HD systems
- ▶ Large HD display – 20.1" widescreen display for compelling presentations and life-like visual communication
- ▶ Powerful HD audio – Four powerful built-in speakers and superior microphone technology for rich stereo sound

Polycom HDX 4000 Series Specifications

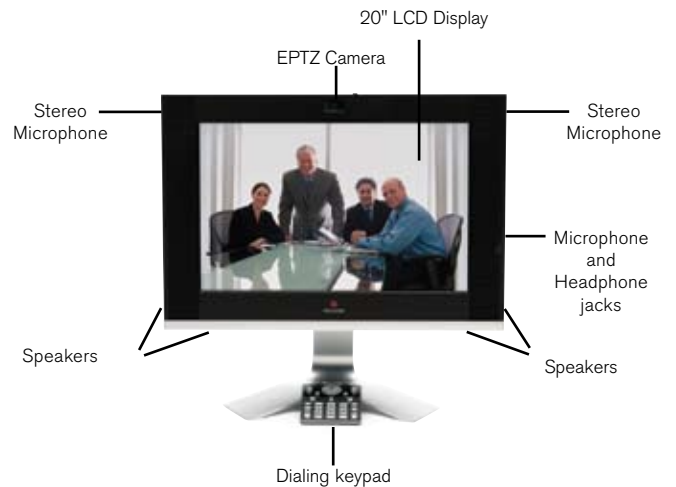
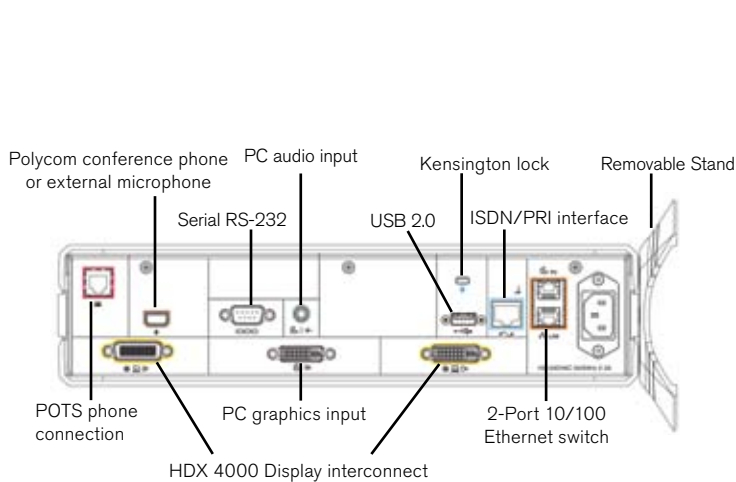

Models

- HDX 4002™ (HD ready)
- HDX 4002 XL (includes content sharing)
- HDX 4001™
- HDX 4001 XL (includes content sharing)

Video Standards & Protocols

- H.264
- H.263++
- H.261
- H.239 / People+Content
- H.263 & H.264 Video Error Concealment

People Video Resolution

- 720p, 30fps at 832 Kbp–4 Mbps (HDX 4002)
- 4SIF (704 x 480)/4CIF (704 x 576) at 256 Kbps–832 Kbp (HDX 4002)
- 4SIF (704 x 480)/4CIF (704 x 576) at 256 Kbps–4 Mbps (HDX 4001)
- SIF (352 x 240), CIF (352 x 288)
- QSIF (176 x 120), QCIF (176 x 144)

Supported PC Input Resolutions

- 1680x1050, 1280x1024, 1280x720, 1024x768, 800x600

Display

- 20.1" widescreen LCD display
- 1680 x 1050 native resolution
- 16:9 Aspect Ratio

Camera

- 5 megapixel camera
- 1280 x 720 video capture resolution
- 65° field of view
- 2x digital zoom
- EPTZ camera control
- Privacy shutter

Speakers

- Frequency range: 85Hz - 20kHz
- Four built-in speakers

Audio Standards & Protocols

- Polycom StereoSurround™
- 22kHz bandwidth with Polycom Siren 22
- 14kHz bandwidth with Polycom Siren 14, G.722.1 Annex C
- 7 kHz bandwidth with G.722, G.722.1
- 3.4 kHz bandwidth with G.711, G.728, G.729A
- Automatic Gain Control
- Automatic Noise Suppression
- Instant Adaptation Echo Cancellation
- Audio Error Concealment
- Headset input for privacy

Other ITU-Supported Standards

- H.221 communications
- H.224/H.281 far-end camera control
- H.323 Annex Q far-end camera control
- H.225, H.245, H.241, H.331
- H.239 dual stream
- H.231 in multipoint calls
- H.243 chair control
- H.460 NAT/firewall traversal
- BONDING, Mode 1

User Interface

- Directory Services
- System Management
 - Web-based
 - SNMP
 - Polycom Converged Management Application™
- CDR
- API support
- International languages (17)
- RSS 2000 integration with HDX remote control
- USB Software Update

Network

- Interfaces
 - 2-port 10/100 auto NIC switch, RJ45 connectors
 - RJ11 analog phone connector
- H.323 up to 4 Mbps (2 Mbps standard)
- SIP up to 4 Mbps (2 Mbps standard)
- RS232
 - Data pass-through
 - Closed caption
- H.320 (Optional)
 - ISDN Quad BRI
 - ISDN PRI T1 or E1
 - Serial (RS449, V.35, RS 530) up to 2Mbps
- Lost Packet Recovery™ (LPR™)
 - Reconfigurable MTU size (IP only)

©2008 Polycom, Inc. All rights reserved.
Polycom and the Polycom logo design are registered trademarks and HDX 4000, HD Voice, People On Content, People + Content, Siren 22, Siren 14, StereoSurround, Lost Packet recovery, LPR are trademarks of Polycom, Inc. in the U.S. and various countries. All other trademarks are the property of their respective owners. Information in this document is subject to change without notice.